

SUBMITTAL: MODEL STH - SAF-T-HATCH Roof Hatch Safety Rail

Railing system with a clamping frame around curb base of roof or fire hatch with top rails, mid rails and chain or swinging gate. Meets OSHA required compliance for safe egress and ingress through rooftop hatch openings while hatch is in use. Complies with OSHA CFF 29-1210.232 and CFR 29 of 1910.27

SPECIFICATIONS:

MATERIALS:

Pipe Rail: 1 5/8" OD A53 Grade B seamed steel.

Tubing Base: Factory galvanized 2" x 2" 16 gauge seamed steel.

Tubing Base Pad: Styrofoam 3/4" thick isolated pad.

Finish: Pre-Galvanized Zinc coated Galvanized pipe (ASTM. A653).

Chain: Zinc plated 3/16" ASTM proof coil with hoop and rings as required.

Accessories: Zinc plated threaded rods, caps, nuts, bolts and washers.

Railing Clamps: JL Industries manufactured models AIS 2-7, 6-7, 18-7, 20-7 and 28-7 or as required

Pipe Caps: Zinc plated post caps with 1 1/4" **UV resistant vinyl side rail caps.**

PACKAGING:

One unit per carton

OPTIONS:

STHG Steel Gate Option for Saf-T-Hatch

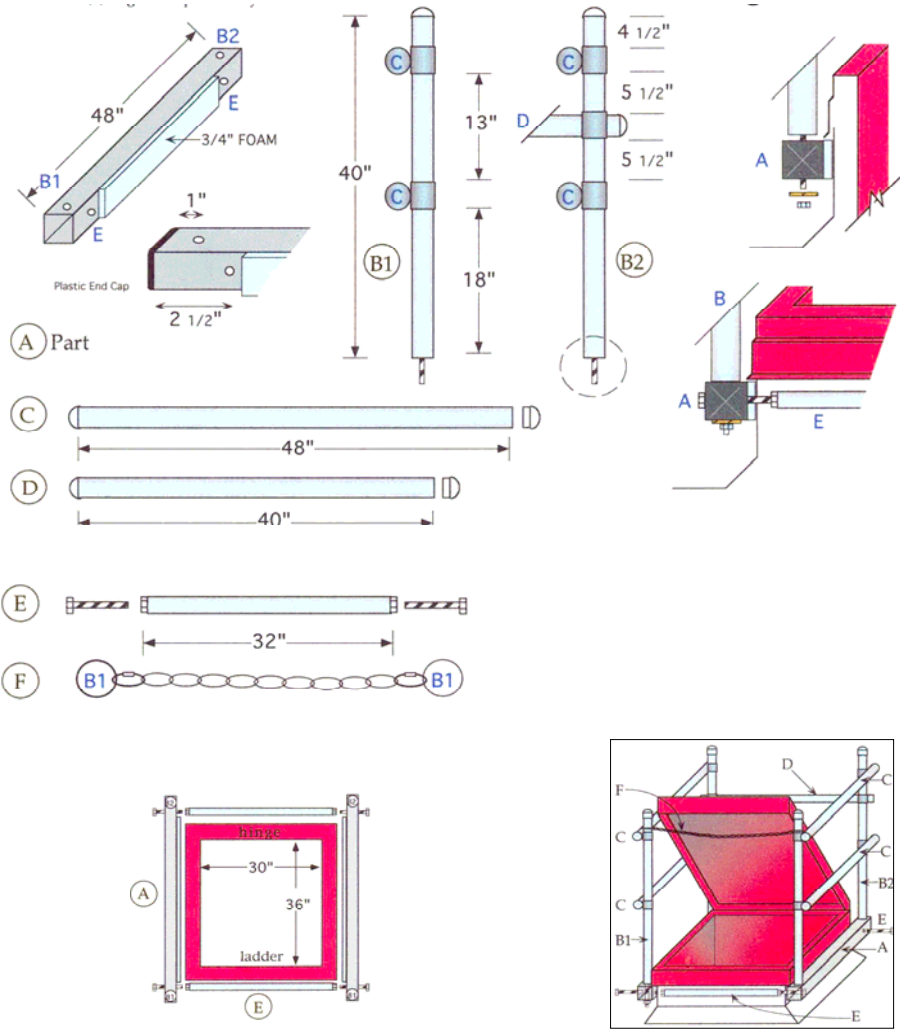

Qty	Model	Hatch OD Dimensions
	STH-1*	30" x 36"
	STH-2	54" x 30"
	STH-3	96" x 30"
	STH-4	36" x 36"
	STH-5	48" x 48"
	STH-3232	24" x 24"
	STH-3238	24" x 30"
	STH-3244	24" x 36"
	STH-3838	30" x 30"
	STH-4456	36" x 48"
	STH-32104	24" x 96"
	STH-44104	36" x 96"

Qty	Model	Width of Opening
	STHG-24	24" Opening
	STHG-36	36" Opening

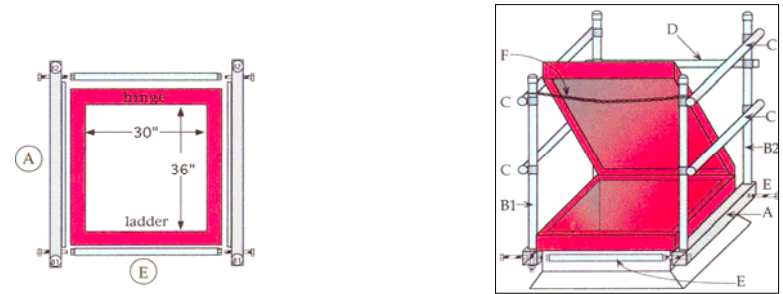
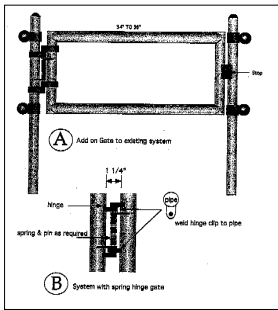

 <p>JL INDUSTRIES</p>	<p>A DIVISION OF</p> <p>ACTIVAR INC.</p> <p>www.activarcpg.com Construction Products Group</p>	Distributor:	Quantity:
		Contractor:	Approved By:
		Model #:	Architect::
		Project:	Date: